



48" BRICK OVEN

COMPONENTS

- 85 FIREBRICK FOR HEARTH (NOT INCLUDED)
- 32" DOME
- OVEN WALL SECTIONS (EIGHT PIECES)
- 24" ENTRANCE TUNNEL (3 PIECES)
- HEAT STOP 50 TWO 50 LBS BAGS
- INSULATING CASTABLE - 20 50# BAGS
- ENTRANCE COVER



Additional materials such as brick, stone or block may be needed for base and surround.

48" BRICK OVEN PLAN VIEW

TECHNICAL DRAWINGS ARE AVAILABLE FOR THESE BRICK OVEN SIZES:

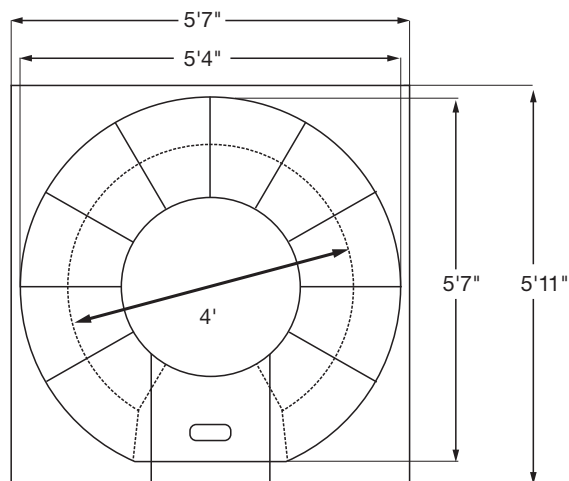
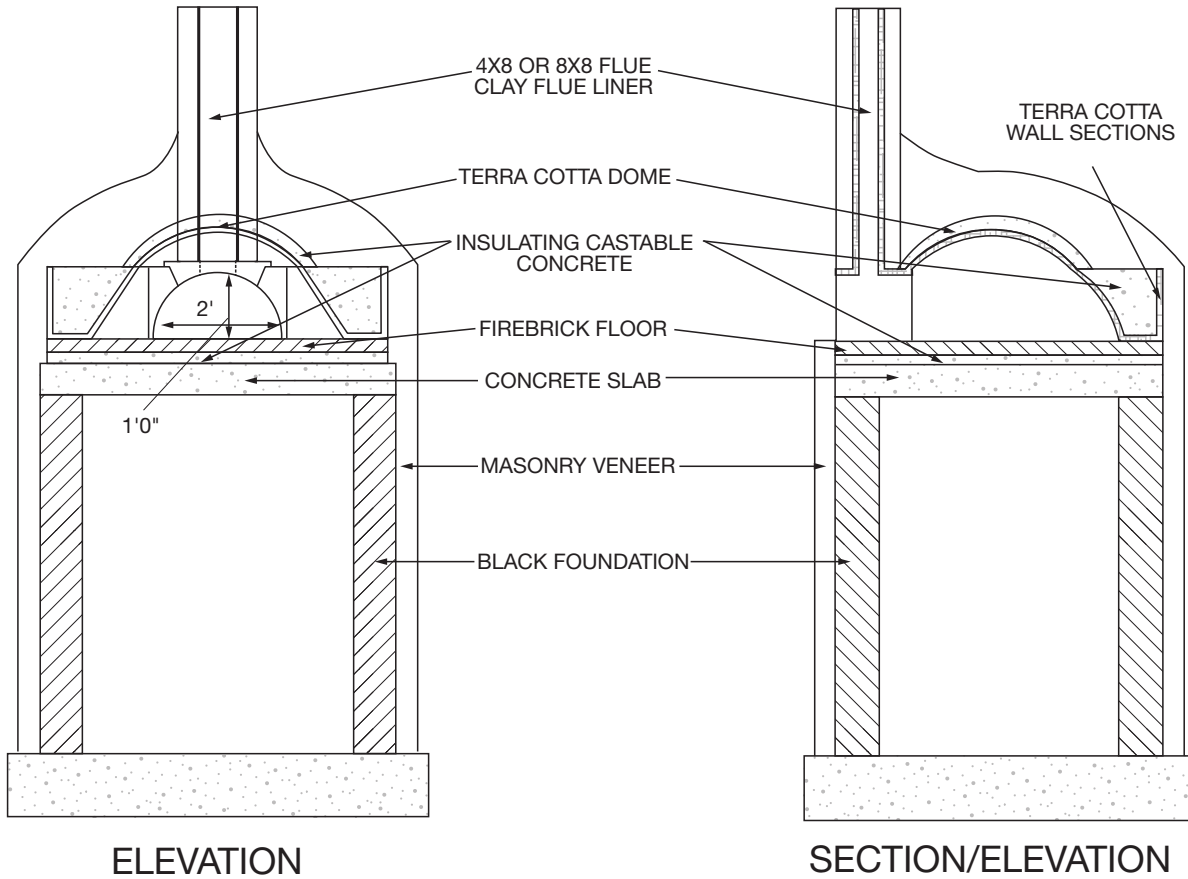

STEP 1



Build masonry base at least 67" wide by 67" deep, and 38" high for a finished oven floor 42" above the kitchen floor or ground.

The inside of the oven is 48" inside diameter. 67" depth will accommodate the oven. Allow additional depth as desired for counter in front of oven door.

STEP 2



Cast a 2" thick layer of insulating refractory concrete on top of the base and set the firebrick oven floor directly on the insulating refractory concrete. Oven outside diameter is 65".

STEP 3



Set wall sections (8 pcs) and the entrance tunnel (3 pcs) as shown using HeatStop II refractory mortar.

STEP 4



Set the 32" oven dome, and the first flue tile all in Heatstop II refractory mortar.

Special note: The dome and sidewalls of the brick oven are likely to crack. Cracking of the dome is not structurally hazardous, and is necessary for natural expansion and contraction of the masonry dome, which will occur during extreme heat fluxuations.

STEP
5



Parge dome with insulating refractory concrete at least 2" thick. Fill cores of side sections and entrance sections with insulating concrete.

STEP
6



The oven can be stuccoed, plastered or finished with any non-combustible masonry material such as tile, brick or stone.

STEP
7



The 4"x8" flue liner should be enclosed within a chimney with walls at least 4" thick of solid masonry. If the chimney is inside a house it must conform to all applicable codes dealing with clearance to combustibles and height above the roof. If the oven is outside the flue need only be enclosed in masonry as high as is desired and clear of combustibles.

STEP
8



An entrance cover for the oven entrance is provided to help keep the oven warm. It can be propped up slightly (to provide combustion air) at the outside of the entrance when a fire is burning in the oven and can be pushed in farther to close off the flue to keep the oven warm longer after the fire has burned out.